

Flat Pattern view
SCALE: 1:10

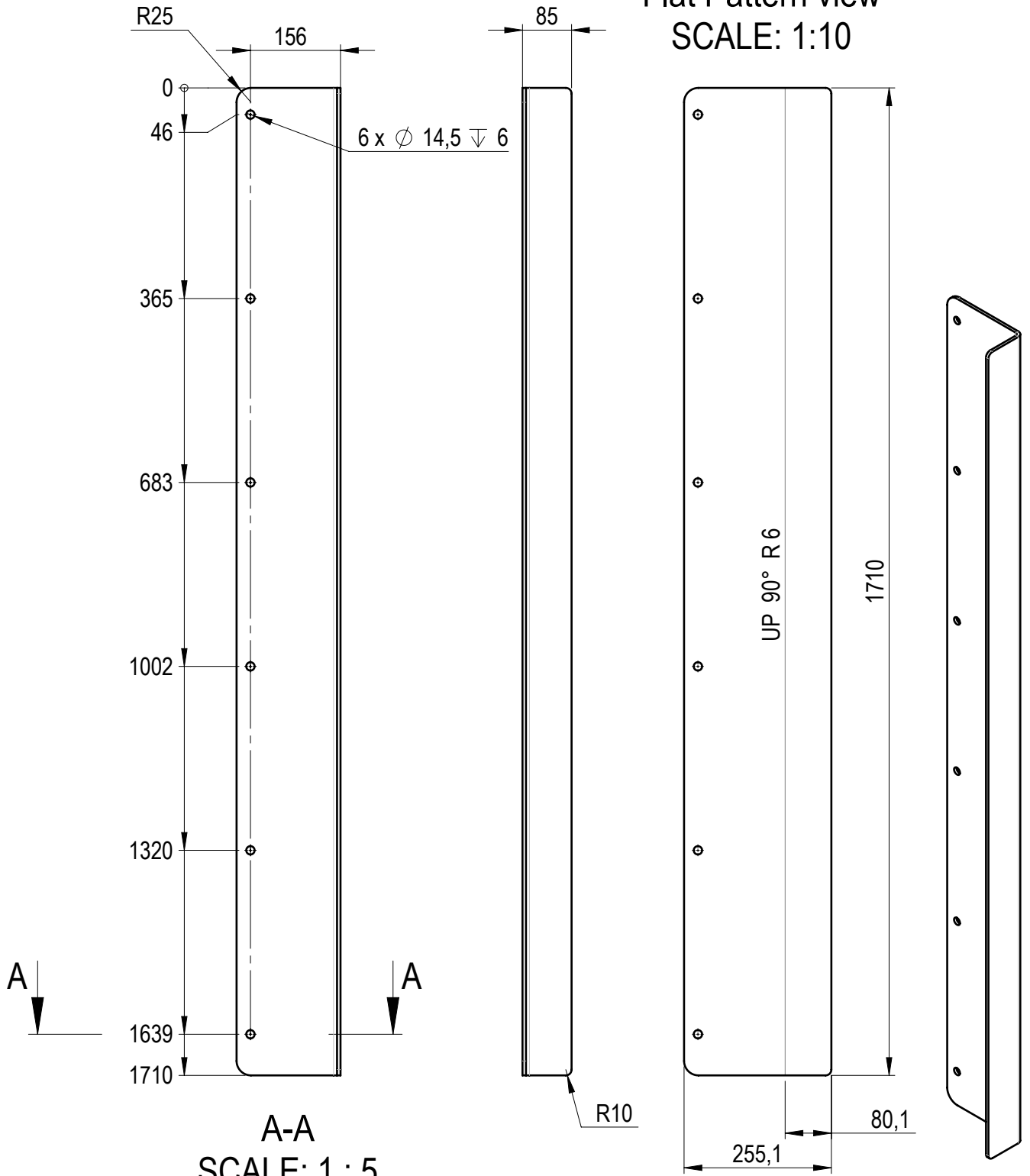

A-A
SCALE: 1 : 5

Other dimensions from .DXF file.

SHEET METAL INFORMATION	
Length, mm	1710
Width, mm	255.1
Thickness, mm	6
Inside Bend Radius, mm	6
K-Factor	0.5
No. of Bends	1

	MATERIAL	S355J2	WEIGHT	20.357 Kg	DEBURR AND BREAK SHARP EDGES	REVISION	DATE	
	SURFACE PROTECTION	HDG EN ISO 1461	MACHINING	ISO 2768 mK	DO NOT SCALE DRAWING		09.07.2025	
	NAME	SIGNATURE	PART NO.	105-30700-01			SCALE	FORMAT
Designed by	A. Menkins			Floor bracket 1			1:10	A4
Drawn by	E. Kriviss							
Technical ref.								SHEET 1/1